

## MACHINE DESCRIPTION

The RT12 tray filler is particularly suitable for filling trays and pots that have to be transplanted: the soil deposited in the cells, in fact, is particularly soft and airy, and represents the ideal condition for transplanting young seedlings.

The soil dropping system is electronically dosed and controlled: this makes the machine versatile and suitable for the use of both light and heavy containers, from polystyrene to thermoformed trays.

The cells are filled with the same amount and degree of compaction of the soil, ensuring uniform growth throughout the container.

Total recovery system of excess soil and cranks for quick self-centring adjustment of the trays.

Thanks to the feeding belt system, the RT12 tray filler can be used both as a stand-alone machine and in a working line.

p. 64-65

## MAIN ACCESSORIES

47 48 49 50 51 55 58

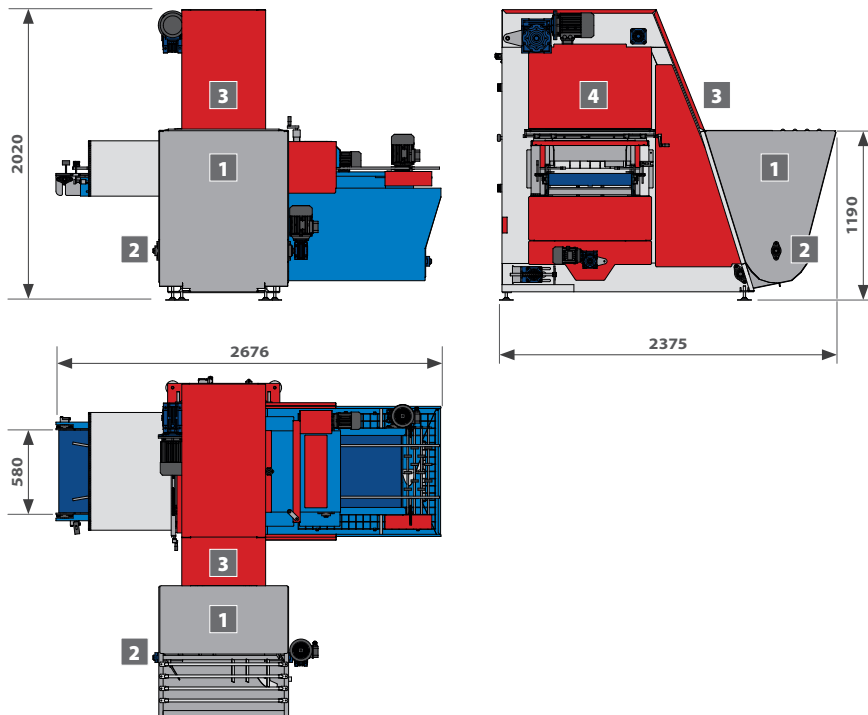

*RT12 left version, accessorized with electric panel on the right side, soil compactor and motorised roller belt with 4 wheel row at the output.*

## TECHNICAL SPECIFICATIONS

- |   |  |
|---|--|
| <ol style="list-style-type: none"> <li>1 Hopper capacity (standard): 600 litres. Conveyor belt on hopper's bottom with rollers.</li> <li>2 Paddles shaft agitator.</li> <li>3 Double chain soil elevator.</li> <li>4 Longitudinal rotor with 4 blades, with electronically adjustable flow rate.</li> </ol> <ul style="list-style-type: none"> <li>• Oscillating spillway and motorized brush for tray cleaning.</li> </ul> | <ul style="list-style-type: none"> <li>• Quick self-centring guide adjustment system.</li> <li>• Recycling system for exceeding soil.</li> <li>• Electric control panel start-stop, emergency and limit switch.</li> <li>• Available in left and right version.</li> </ul> |
|---|--|

TECHNICAL DATA	M.U.	RT12	RT12 A	RT12 E
HOURLY PRODUCTION (max)	trays/hour	600	600	600
HOPPER CAPACITY (standard)	l	600	600	600
TRAYS DIMENSIONS (max)	mm	600x400	750x400	750x500
TRAYS HEIGHT (max)	mm	220	220	220
INSTALLED POWER	kW	4	4	4
WEIGHT	kg	790	790	790



**RT12**  
TRAY FILLER - up to 600 trays/hour



# MAIN ACCESSORIES

## TRAY FILLERS

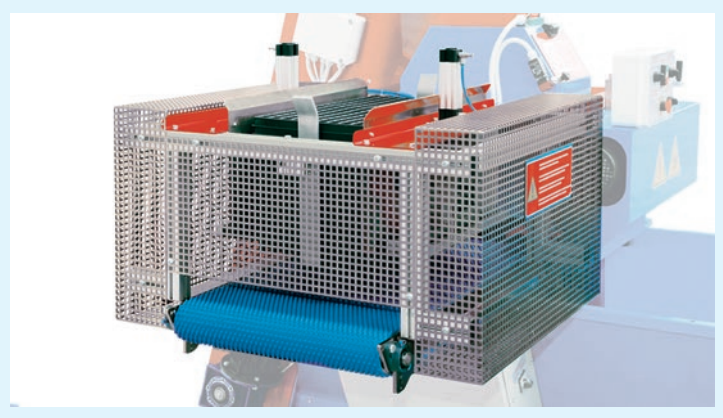

Electropneumatic **3-movements destacker**, for thermoformed trays PE - PET. **47**

**AVAILABLE ON:**

RN12, RT12, RE14, RC65

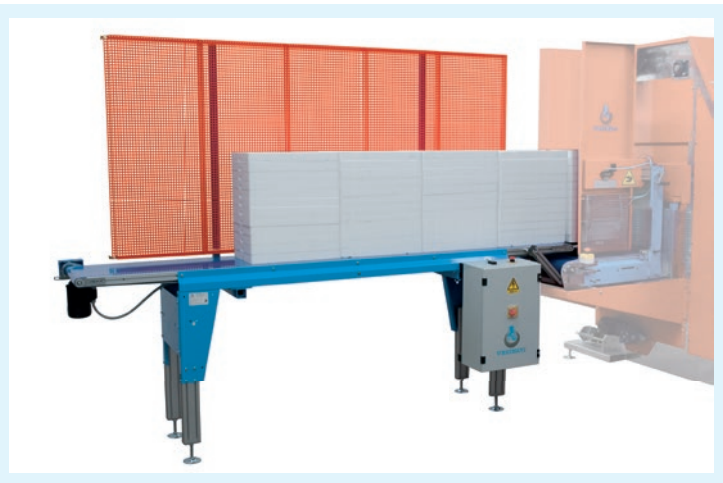

**Feed belt** for single trays or empty stacks for destacker  
L = 3300/4300/5300/6300 mm. **50**

**AVAILABLE ON:**

RN12, RT12, RE14, RC65



Electropneumatic **destacker with 2-movements**, adjustable with a single crank; for polystyrene trays and trays holder. **48**

**AVAILABLE ON:**

RN12, RT12, RE14, RC65



**Destacker** for heavy plastic trays at injection in polypropylene PP. **49**

**AVAILABLE ON:**

RN12, RT12, RE14, RC65

- Advancement belt with electronically **adjustable speed from 200 to 800 trays/hour**.
- **Soil compactor** with rotating movement and eccentric for **adjustable density**.
- Device **for hopper emptying** with frequency driver.
- Soil hopper extension with **additional capacity of 500 liters**.

**AVAILABLE ON:** RT12

- **Vibrating table** on conveyor belt.

**AVAILABLE ON:** RN12, RT12, RE14, RC65



These are **some of the accessories available** for our **soil tray filler**.  
Our **engineering dept.** is at your disposal **to suggest the best solutions** for your needs.

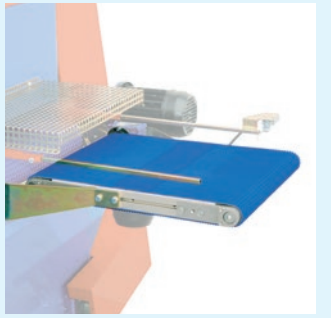

**51** **Acceleration belt**  
530 mm at the outlet  
for the connection  
to other machines.

**AVAILABLE ON:**  
RN12, RT12, RE14, RC65

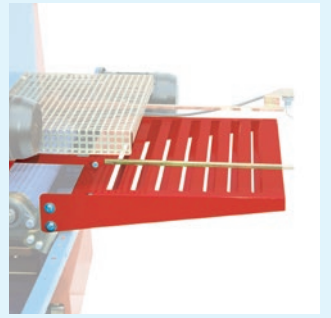

**52** **Fixed table** positioned  
at tray filler exit.

**AVAILABLE ON:**  
RC65, RE14



**53** **Belt system** for the  
exceeding soil recycle.

**AVAILABLE ON:**  
RC65, RE14



Quick self-centring guides adjustment system.

**AVAILABLE ON:**  
RN12, RC65, RT12



**55** **Hopper 900 liters.**

**AVAILABLE ON:**  
RN12, RT12



**56** **Hopper 1000 liters,**  
complete with bulkhead  
and nr. 2 turning wheels.

**AVAILABLE ON:**  
RC65, RE14

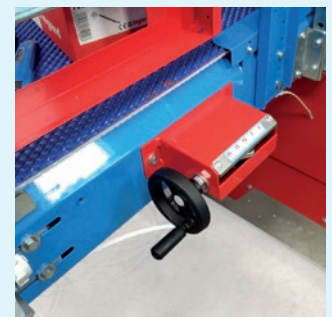

**57** **Adjustment device**  
for trays with legs.

**AVAILABLE ON:**  
RN12, RC65, RE14

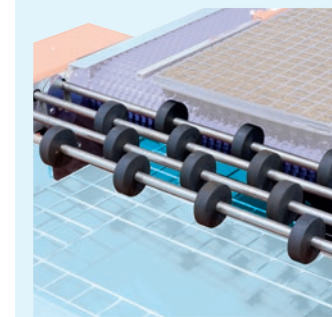

**58** **Motorized exit roller,**  
with nr. 4 rows.

**AVAILABLE ON:**  
ALL TRAY FILLER



**59** **Wheels kit** for handling.

**AVAILABLE ON:**  
RC65, RE14

