



# RGV

up to 400 liters/min - FILLING MACHINE FOR BIG VOLUME



*RGV equipped with double air-blower kit for containers cleaning and wheels kit for machine positioning.*

## MACHINE DESCRIPTION

The range of Urbinati soil fillers is enriched with a new high-performance machine: is the automatic filler for pots, trays and pack called RGV. Core of this machine is the soil elevator: its large size allows to process a huge flow of soil, while the double chain of the elevation system, sturdy and galvanized, minimizes maintenance operations over time, preserving and getting longer the machine efficiency.

With a flow rate up to 400 liters/minute, the RGV allows you to quickly and uniformly fill containers up to 450 mm in height, and to set density and final compaction of the soil inside them thanks to the longitudinal rotor drop system made up by 4 blades. Electromechanical machine operation, with the possibility of installing PLC for complete remote management.

The RGV filler also has an efficient system for recovering the excess soil that allows it to be put back into circulation for over 80%: this feature, combined with the large hourly production and the reduced maintenance required, make this machine a guarantee in terms of optimization of time and resources.



| TECHNICAL DATA                      | M.U.            | RGV       |
|-------------------------------------|-----------------|-----------|
| HOURLY PRODUCTION with pot Ø 300 mm | pots/hour       | 1200      |
| HOURLY PRODUCTION (max)             | containers/hour | 1200      |
| SOIL ELEVATOR CAPACITY              | l/min           | 400       |
| CONTAINERS HEIGHT (min-max)         | mm              | 30 - 450  |
| CONTAINERS WIDTH (min-max)          | mm              | 150 - 450 |
| INSTALLED POWER                     | kW              | 4,5       |
| WEIGHT                              | kg              | 1300      |



## TECHNICAL SPECIFICATIONS

- 1 Hopper capacity 750 liters, with paddle shaft agitator on the bottom for a complete emptying.
  - 2 Soil elevator with double galvanized and sturdy chain: width 800 mm, flow rate up to 400 liters/min.
  - 3 Adjustable speed conveyor belt: from 2.5 to 12 m/min.
  - 4 4-blade longitudinal rotor: height adjustable with crank, electronically adjustable speed.
  - 5 Compactor drum, spillway and brush for cleaning containers with adjustable height with cranks.
  - 6 Motorized outfeed roller conveyor with 8 rows of rollers.
  - 7 Remote control panel with potentiometers, which can be positioned on all sides of the machine.
- Soil loading hopper that can be positioned on the right or left hand of the belt.

- Containers for strawberry transplanting, combined: **up to 2.400 containers/hour.**



Pots dimension up to:  
 $\varnothing = 450 \text{ mm}$ ,  $h = 450 \text{ mm}$

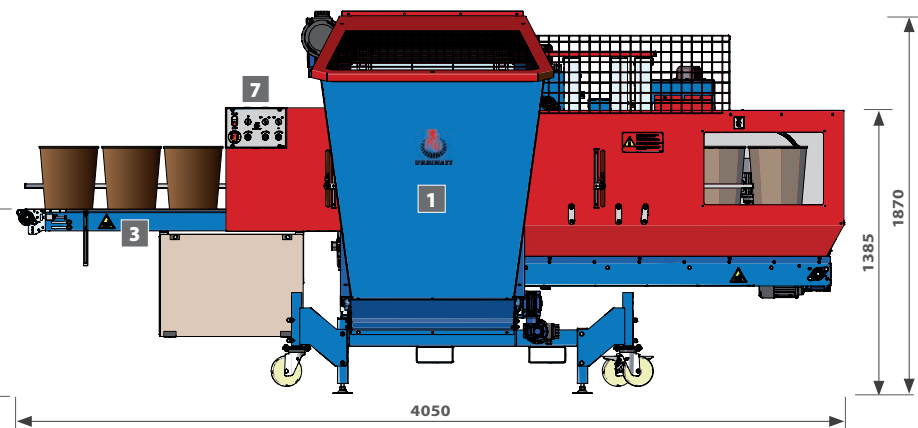
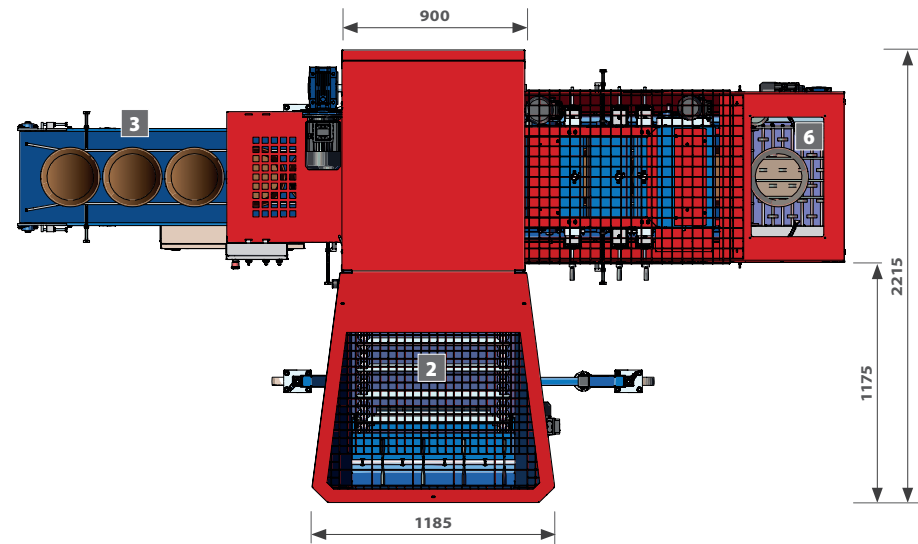
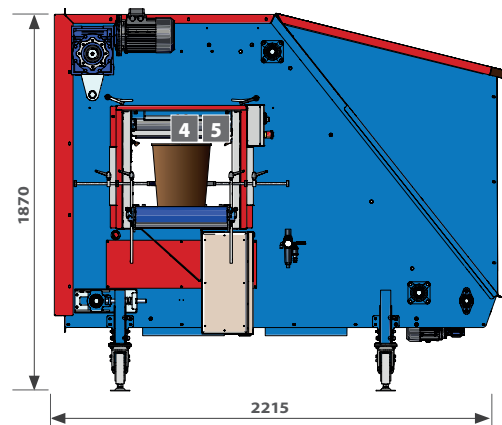

## MAIN ACCESSORIES

- **Controlled by PLC**, for an easy and complete management of the machine through the **touch-screen panel**. It is possible to set and save **up to 99 programs**. This device allows the machine to **communicate with a remote system** (internet interconnection).
- **Double air-blower** kit for containers cleaning.
- **Hopper emptying option** at the end of the cycle, with inverter.
- **Heavy duty wheels kit** for machine positioning.

