

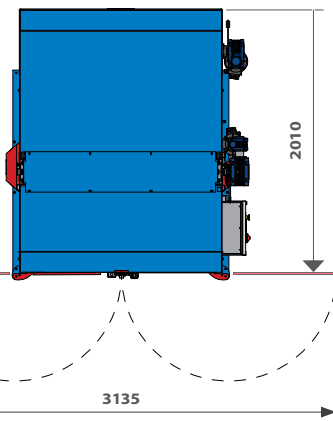

CARBB

VERTICAL BIG-BALE BREAKER - Machine that processes soil compressed in bales

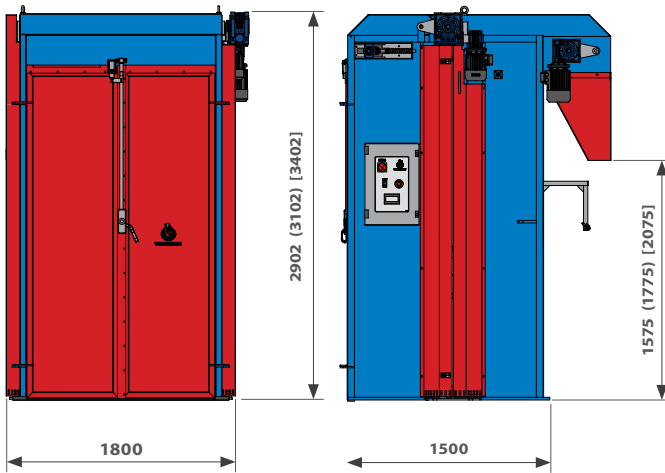

The **CARBB vertical big-bale breaker** is capable to confer homogeneity and uniformity to the soil thanks to the combination of bale's raising and horizontal scraping system making it ready to use. The CARBB may be used upstream of seeding, filling, potting, mixing and pressing machines.

TECHNICAL DATA	M.U.	CARBB 2400	(CARBB 2600)	[CARBB 2900]
HOURLY PRODUCTION (max) bales/hour		3	3	3
BALE DIMENSIONS (max) mm		1200x1200	1200x1200	1200x1200
BALE HEIGHT (max) mm		2400	2600	2900
WEIGHT kg		1500	1550	1620
INSTALLED POWER kW		3	3	3

Controlled by a PLC, the operator has just to get the bale in and start the process through the external control panel. Different sensors give you info on drop height, bale's operating status and when the soil is run out.



heavy-duty
efficient
safe to use
customizable



URBINATI
Nursery Technology



www.urbinati.com - info@urbinati.com

via Della Liberazione, 18 I-47030 San Mauro Pascoli (FC) - Italy - Tel. +39 0541 932018