



IA3500

up to 7.000 pots/hour - AUTOMATIC POTTING MACHINE



Video



MACHINE DESCRIPTION

IA3500 automatic pottling machine: it is the new-generation pottling machine, completely electromechanical and manageable from a remotable control panel, equipped with a colour touch-screen, for maximum flexibility of use.

The machine is used to store the settings for each specific pot size used, thus reducing the changeover times from one pot size to another during production.

It is equipped with a 3-movements pot destacker with integrated "pot counter" function, which is used to program work for a set number of units, thus simplifying the operator's work, where needed.

Output belt speed adjustable by PLC, as well as many other functions, which can be easily set from the remote control panel.

Automatic soil feeding system as standard supply, with recovery and recirculation of excess material. Supplied, metal drill diam. 40 mm with plate and pot output belt. L = 4000 mm.

Pot carousel available in clockwise or counterclockwise rotation.

DETAILS

p. 54-55



IA3500 with single head: pots in output from the carousel.

| TECHNICAL DATA | M.U. | IA3500 |
|--|-----------|--------|
| HOURLY PRODUCTION (max) - double head with pot Ø 8 - 13 cm | pots/hour | 7000 |
| HOURLY PRODUCTION (max) - single head with pot Ø 8 cm | pots/hour | 4500 |
| HOURLY PRODUCTION (max) - single head with pot Ø 27 cm | pots/hour | 2500 |
| HOPPER CAPACITY | l | 1600 |
| BELT LENGHT (standard) | mm | 4000 |
| WORKING HEIGHT | mm | 900 |
| INSTALLED POWER | kW | 5 |
| WEIGHT | kg | 1600 |



TECHNICAL SPECIFICATIONS

- 1 Hopper capacity 1600 liters; bottom of the belt hopper with sliding on rollers.
- 2 3-movements pot destacker for round thermoformed or injection pot, with single separator.
- 3 Single-headed pot carousel (pot diam. 8 ÷ 27 cm).
- 4 Pot output belt L = 4000 mm, with adjustable speed.
 - Excess soil recirculation system.
 - Height-adjustable support feet.
 - Metal drill diam. 40 mm with plate; fixed speed.

p. 56-57

MAIN ACCESSORIES

36 37 38 39 40 41 42 43 44 45

- Electromechanical version with **tech adjustments**.
- Pot carousel kit for **double head** (pot diam. 8 ÷ 13 cm).
- 5 3-movements **pot destacker** with **double pot separation** device.
- **Pot output belt** available in the variants L = 5000 / 6000 mm.
- **Motorised spillway** with 4 rotating blades.
- **Wheels kit** with drawbar for handling.
- **Metal drills with plate**, diam. from 30 to 120 mm.
- **Speed variator** for drills.
- **Modification kit for square pots** use.



Video

Pots feeding belt, combined with **double head for square pots** (accessory).

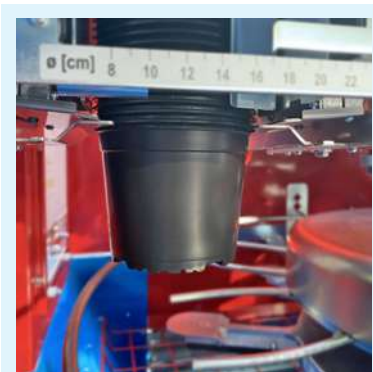
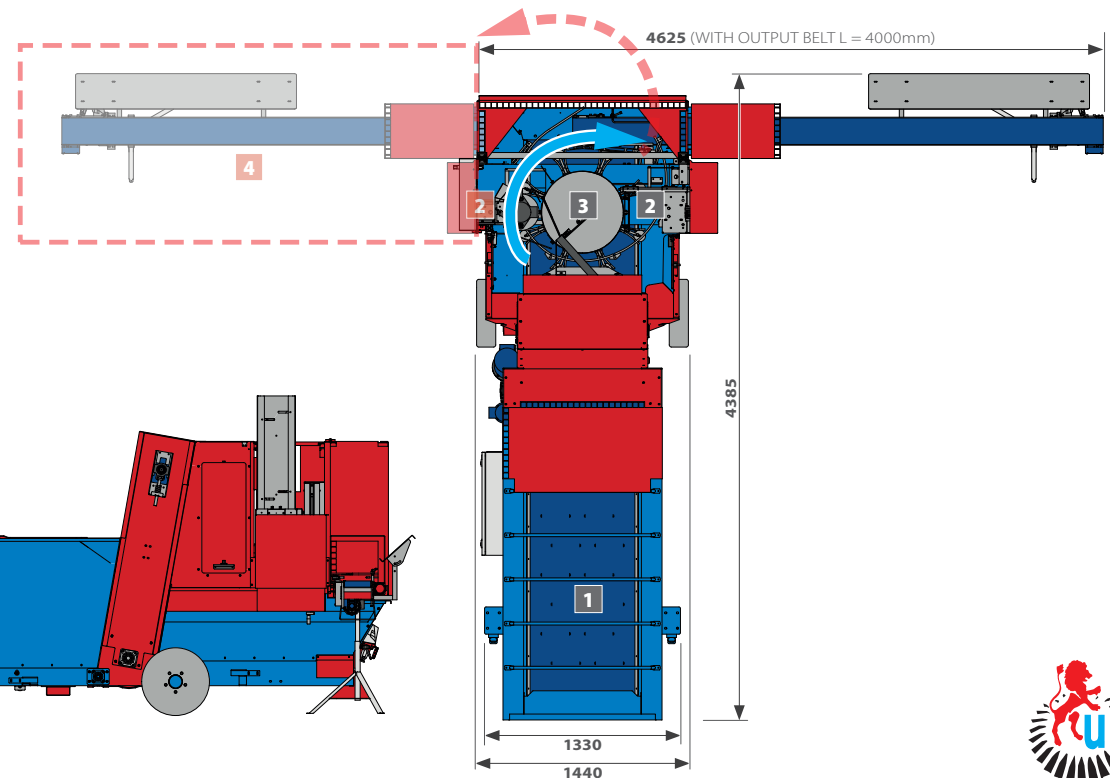

5

Double pot separation device (accessory)

